

Chemical industry

Specialy custom designed bearing integrated seal for a bottom entry powder mixer

45 mm (1.7") shaft, 50 rpm, in servic for over 4 years.

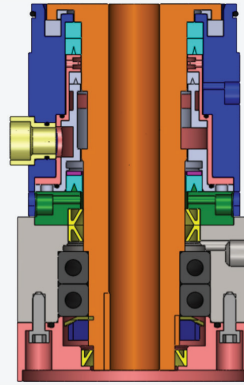

Mineral industry

custom designed, bearing integrated seal and construction modification for a magnetic separator

40 mm (1.5") shaft, 80 rpm, in service for over 2 years.

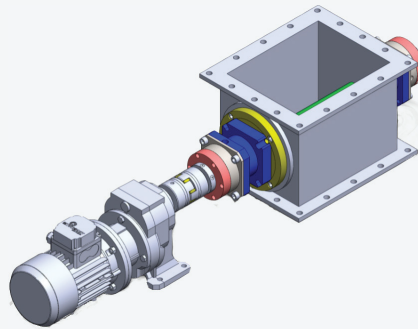

Oil industry

split seals on a twin shaft mixer for heavy sludge

150 mm (6") shaft, 20 rpm, in service for over 5 years.

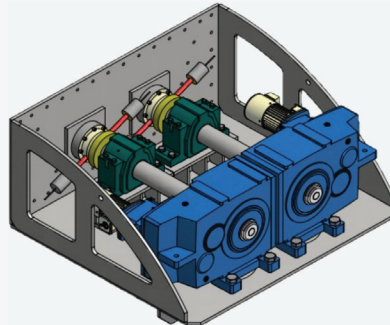

Chemical industry

speacially designed bearing integrated seals for a twin shaft chopper

40 mm (1.5") shaft, 90 rpm, in service for over 2 years.

